



KaIGUARD[®]

Installation Manual

Water Treatment Equipment to
Manage Hardwater Limescale

Version 3 – April 2018

IMPORTANT

Please leave a copy of this manual with the KaIGUARD equipment in its plant room

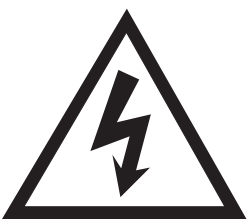

WARNING:

The KalGUARD Controller circuit boards have live connections and should only be accessed by a competent person.

Section	Page
<u>Installation Advice</u>	<u>4</u>
System and Component Arrangement	4
Typical Installation	5
General Notes	6
Specification Tables	7
Component Checklist	8
Principle Installation Guidelines	9
Installation Schematics	10–12
Concluding the Installation	13
Pipework Sanitation	13
Preparing the KalGUARD for Commissioning	14
<u>Technical Description: MK1 Controller</u>	<u>15–17</u>
<u>Technical Description: MK2 Controller</u>	<u>18–19</u>
<u>Water Meter</u>	<u>20</u>
<u>Water Filtration</u>	<u>21</u>
<u>Pulse Splitter User Instructions</u>	<u>22–23</u>
<u>Health & Safety</u>	<u>24</u>
<u>Servicing & Monitoring</u>	<u>25</u>
Service Contract	25
Recommended Monitoring	25
Other Service Considerations	25
Automatic Servicing	25
<u>Commissioning Details</u>	<u>26</u>
<u>Trouble Shooting</u>	<u>27–28</u>
<u>Service Log</u>	<u>29–31</u>
Please copy page 31 if additional sheets are needed	

Please visit www.sentinelprotects.com/uk/guarantee-registration for Guarantee Registration and Terms and Conditions.

KalGUARD is a registered Trade Mark and is protected by CTM 012658688 owned by Sentinel Performance Solutions Limited.

Installation Advice

SYSTEM AND COMPONENT ARRANGEMENT

It is important to ensure that the KalGUARD system components are installed in the same water flow line, as per Fig. 1. They should typically be arranged in a 'side-stream loop' to the main water feed line. It should be possible to place the side-stream loop in or out of service by the operation of isolation valves on the loop and a by-pass valve on the main water feed line.

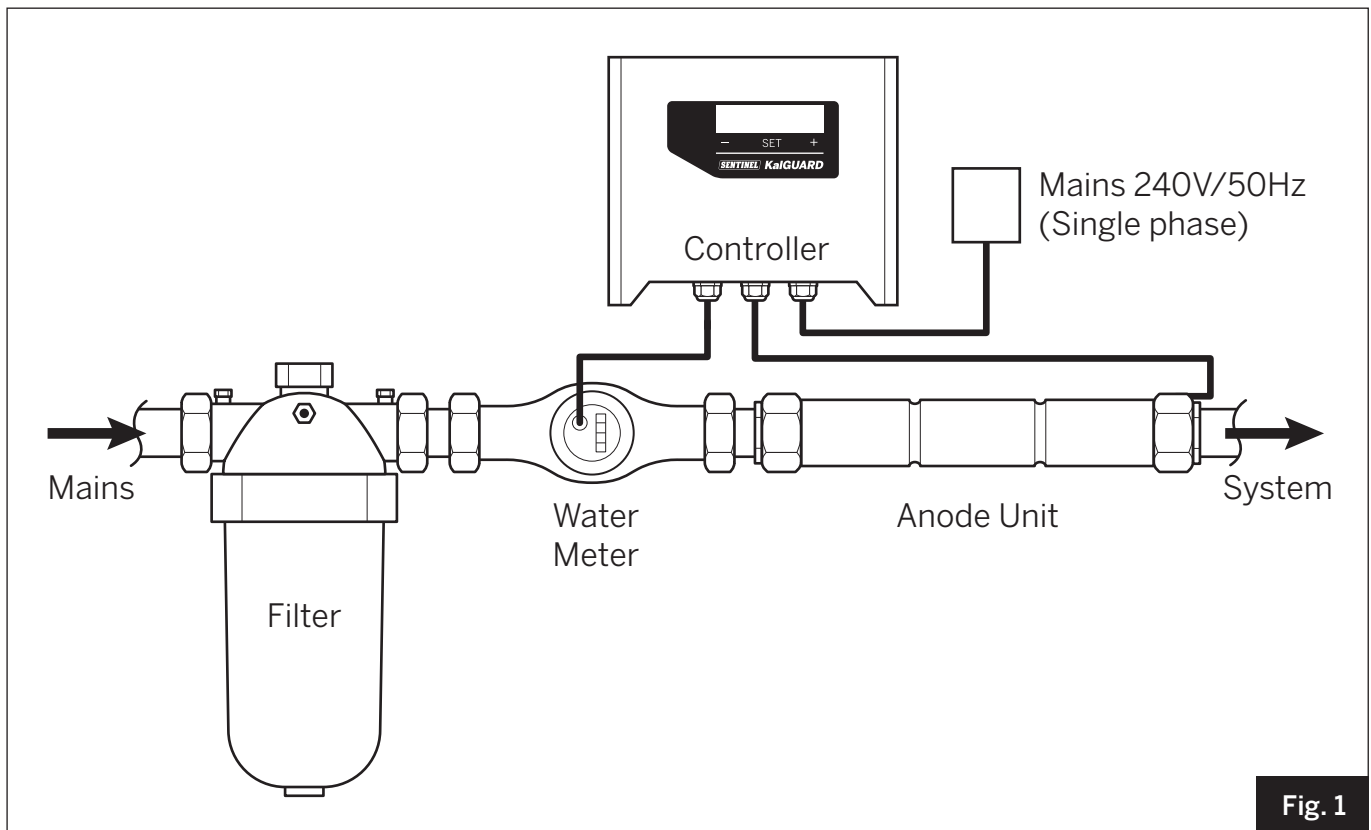

Fig. 1

KalGUARD Anode Unit

This component contains a zinc anode which continuously doses small amounts of zinc ions into the water passing through it to inhibit scale formation.

KalGUARD Controller

The controller links with the water meter to automatically match the output of zinc ions to water flow.

25/55 µM Water Filter

Filtration of incoming mains water to $\leq 50\mu\text{m}$ is recommended to ensure optimum performance of the equipment. For all pipe sizes up to 108mm (4"), the filter supplied will be a "stacked disc" type. The filter must always be installed upstream of the KalGUARD anode unit.

Water Meter

The water meter provides essential data to the KalGUARD controller to ensure intelligent activation of the KalGUARD anode unit. It is NOT intended for direct paralleling with a BMS for volumetric water coupling (see later – "Installation of Electrics/ Electronics").

Following the completion of the installation, please refer to the check list on page 14 **before** contacting Sentinel on 01928 704 330 to arrange **COMMISSIONING**.

TYPICAL INSTALLATION

When installed, the KaIGUARD 'kit' will have this general appearance.

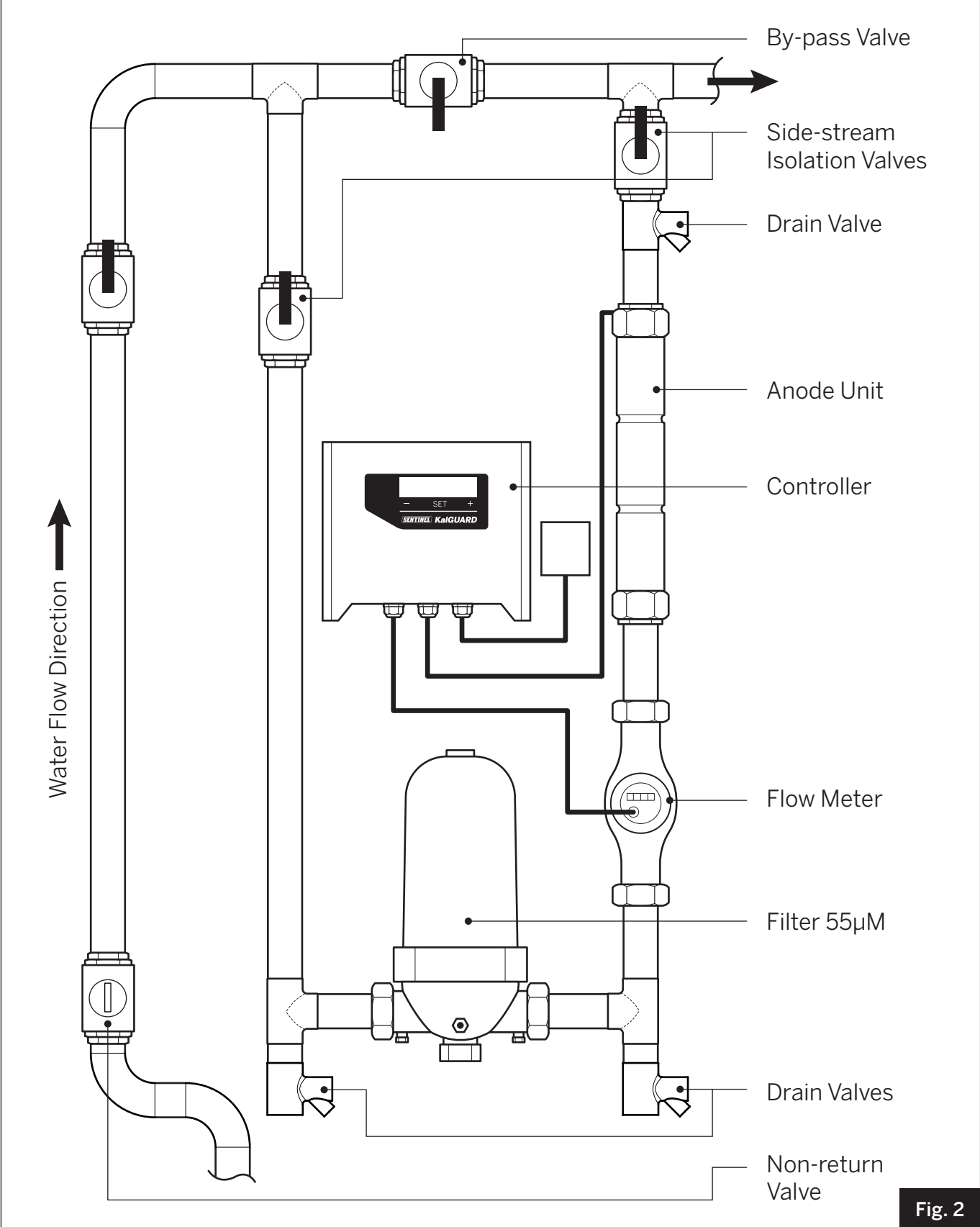

Fig. 2

Installation Advice

GENERAL NOTES

Note 1:

The following items are also required for installation, but not provided with the KalGUARD 'kit' depending on installation configuration: (See fig 2 for reference)

- Delayed action inlet valve
Where the equipment is installed on a water system feeding a preliminary break tank of < 10m³ (prior to a water system booster set) the break tank inlet water valve should be a "delayed action" type. This is to ensure fast or full flow from the mains when actuated.
- Non-return valve
- Quarter-turn isolating valves
Up to three required – refer to the appropriate installation diagram.
- Drain valves
Up to four required – refer to the appropriate installation diagram.

Note 2:

Lagging is recommended. All cold metal pipework surfaces encourage condensation which can be prevented by appropriate fixed lagging. The KalGUARD anode unit should have a removable insulating jacket held closed by Velcro strips and its ends closed with draw strings or tapes. A similar arrangement will protect the flow sensor water meter.

Note 3:

It is preferable to install the KalGUARD onto the incoming mains water line for whole water system protection. Where this is not possible, it can be applied to just the hot water system to protect commercial and industrial water heaters. The intention is also to maximise protection for the downstream hot water pipework. This can also become fouled in areas where water supplies have high mineral content ('hard' water) and consequently high potential for causing flow-restricting limescale deposits.

Note 4:

The combination of the water flow meter and system controller provides intelligent operation of the KalGUARD anode unit. This reactive intelligence limits operation of the KalGUARD system during periods when there is low or no water flow and maximises effective treatment at other times.

Note 5:

It is important that ALL INSTALLATIONS HAVE EASY ACCESS FOR MAINTENANCE PURPOSES.

Note 6:

The side-stream configuration allows the maintenance engineer to divert the water flow via the by-pass section during servicing and thus ensure no interruption of the water supply to the building. The only variation that can apply is that the water flow meter may instead be mounted in the adjacent common pipework. Where the unit feeds a cold water storage tank, the side-stream configuration can sometimes be omitted. This is only the case where the storage tank will supply adequate water to allow servicing to take place.

Note 7:

The KalGUARD anode unit is WRAS approved and is safe to install in drinking water pipework.

Note 8:

Only the water meter supplied by Sentinel can be used with the KalGUARD system.

KALGUARD SPECIFICATION TABLE – ANODE UNITS

Product Code	Length	Diameter (Main Body)	Weight (KG)	Design Flow (l/m)	Design Flow m ³ /h	Connection	ΔP (bar) @ Design Flow
KALG22	375	42	2.5	37	2.22	¾" BSP Female	0.15
KALG28	450	54	3.1	64	3.84	1" BSP Female	0.13
KALG35	484	67	4.6	96	5.76	1 ¼" BSP Female	0.23
KALG42	505	67	4.9	142	8.52	1 ½" BSP Female	0.26
KALG54	525	76	6.4	255	15.3	2" BSP Female	0.26
KALG67	650	108	16.8	423	25.38	2 ½" 8 bolt DIN/ANSI Flange	0.20
KALG76	650	134	30.0	523	31.38	3" 8 bolt DIN/ANSI Flange	0.23
KALG108	650	160	37.0	1099	65.94	4" 8 bolt DIN/ANSI Flange	0.20

KALGUARD SPECIFICATION TABLE – CONTROLLERS

Version	For	Width (mm)	Height (mm)	Depth (mm)	Display	Display	BMS Connectivity	IP Rating
Mk 1	67, 76, 108mm KG	193	180	103	LCD	240 V AC	Fault Alert, Optional Pulse Splitter	65
Mk 2	22, 28, 35, 42 & 54mm KG	259	213	66	OLED	240 V AC	Fault Alert, Remote Switching (on/off), Optional Pulse Splitter	65

KALGUARD SPECIFICATION TABLE – WATER METERS

KG Size	Water Meters (in)	Length (mm)	Width (mm)	Height (mm)	Weight (KG)	Connections	Qmax* (m ³ /h)	Qn* (m ³ /h)	Qmin (l/h)	Max Pres. (bar)	K Value (litre)	ΔP (bar) @ Design Flow
22	¾"	190	99	107	1.7	¾" BSP Male	5	2.5	50	16	1	0.20
28	1"	160–260	104	115	2.6	1" BSP Male	7	3.5	70	16	1	0.35
35	1 ¼"	160–260	104	120	3.1	1 ¼" BSP Male	12	6	100	16	1	0.38
42	1 ½"	200–300	125	148	5.2	1 ½" BSP Male	20	10	200	16	1	0.20
54	2"	300	125	173	8.5	2" BSP Male	30	15	450	16	1	0.23
67	2 ½"	200	65	200	10.1	PN16 Flanges	50	25	750	16	10	0.06
76	3"	200	80	270	13.8	PN16 Flanges	80	40	1200	16	10	0.03
108	4"	250	100	270	18.2	PN16 Flanges	120	60	1800	16	10	0.05

*Qmax = Max flow (short period)



*Qn = Nominal flow

KALGUARD SPECIFICATION TABLE – FILTERS

Connection Size	For	Length (mm)	Width (mm)	Height (mm)	Weight (KG)	Connection Diameter (mm)	Average Flow (m ³ /h) @ 55u	ΔP (bar) @ Design Flow
1" Short	22mm KG	158	130.0	233	1.1	25	3.15	0.11
1" Super	28mm KG	158	130.0	340	1.42	25	4.2	0.05
1 ½" Super	35mm KG	200	130.0	350	1.5	40	6.3	0.12
2" Leader	42 & 54mm KG	230	215.0	425	3.2	50	11	0.28
3" Leader	67mm KG	742	228.0	320	6.3	90	22	0.17
4" Leader	76mm KG	1188	319.0	445	28.8	110	42	0.05
6" Leader	108mm KG	1188	319.0	415	30.4	160	49	0.06

Installation Advice

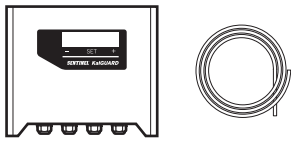
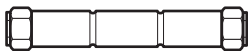
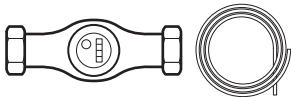
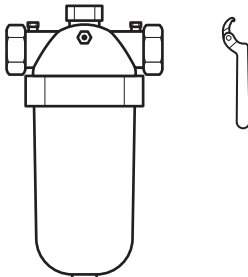
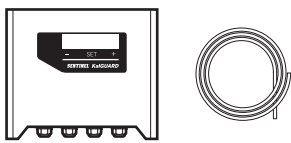
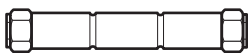
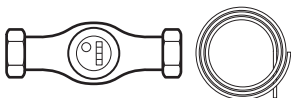
COMPONENT CHECKLIST

Full Pack	
Controller with anode unit supply cable	
Anode Unit	
Water Meter with cable	
Filter (with C-spanner on 22mm – 54mm range)	
Part Pack	
Controller with anode unit supply cable	
Anode Unit	
Water Meter with cable	
Optional extra for both packs	
Pulse Splitter with cable	

PRINCIPLE INSTALLATION GUIDELINES

- Mechanical connections to the anode unit and water flow meter must be demountable to facilitate the servicing of both units.
- There must be at least three metres of direct pipeline between the anode unit and the plant. Additional pipework should be added (as a coil or serpentine) to ensure this is achieved.
- The equipment should always be installed as a side-stream to the main water feed-line so that it can be easily isolated for maintenance.
- The filter must always be installed upstream of the anode unit.
- If the anode unit can be placed on the in-coming water main then the whole building will benefit from the protection the unit can provide.
- The single bowl filter orientation must always be vertical. **Ensure, however, that the orientation is such that the bowl sits 'below' for sizes 1", 1¼" and 1½" and 'above' for 2".** The 2" size has a drain valve into the pipework body part for ease of maintenance.
- At least 50mm (2") vertical clearance must be allowed for the filter bowl (to facilitate servicing).
- The water flow meter can be installed anywhere on the side-stream loop or, if necessary, on adjacent common pipework. It must always be mounted in the same water flow as the anode unit.
- Use a NRV (non-return valve), "¼ turn" isolating valves and drain valves as shown in the schematic diagrams.
- All pipework and fittings should be assembled to facilitate easy access for maintenance.
- Pipework earthing must comply with the latest electrical safety regulations.

Installation Advice

INSTALLATION SCHEMATICS

Note:

All the installations on the following pages show two drain valves to which hoses may be connected. This is to facilitate draining the side-stream prior to servicing and to assist cleaning.

Schematic 1: Horizontal Pipe

For horizontal pipe mounted along a wall well above ground level.

This is the most typical installation where the incoming pipe to the building, or main feed to the water system involved, is mounted on a wall and is a metre or more from the ground.

The installation point should allow full service access and should not be obscured by other equipment.

Servicing the filter requires 50mm vertical clearance for removal of the filter bowl. There must also be good access to the anode unit. Access for periodic inspection of electrical components should also be available.

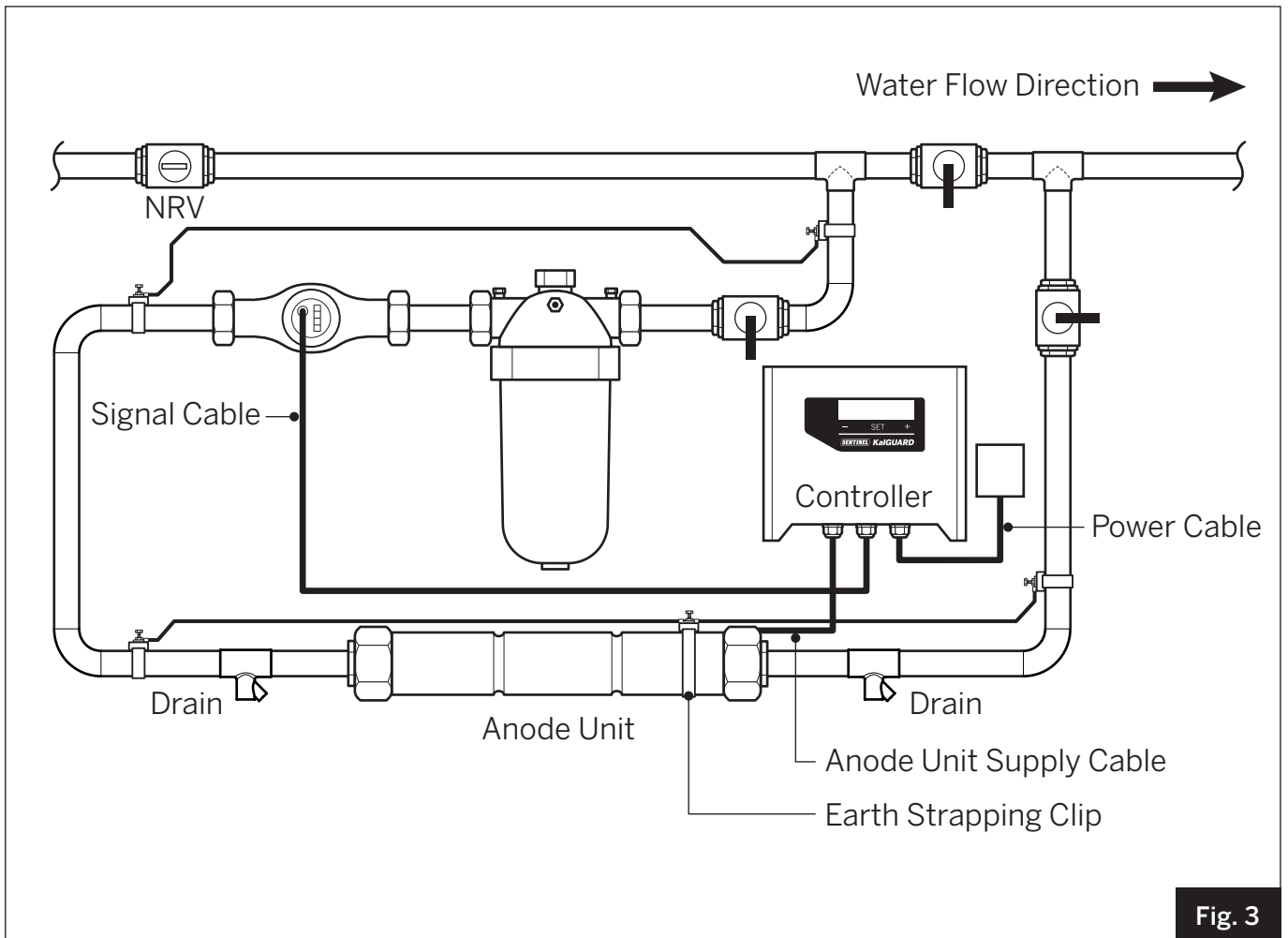

Fig. 3

INSTALLATION SCHEMATICS (continued)

Schematic 2: Horizontal Pipe

For horizontal pipe run at low level at point of installation.

This is the most appropriate installation where the incoming pipe is run along the lower part of the wall or is just above floor level. Servicing the filter requires 50mm vertical clearance for removal of the filter bowl. There must also be good access to the anode unit. Access for periodic inspection of electrical components should also be available.

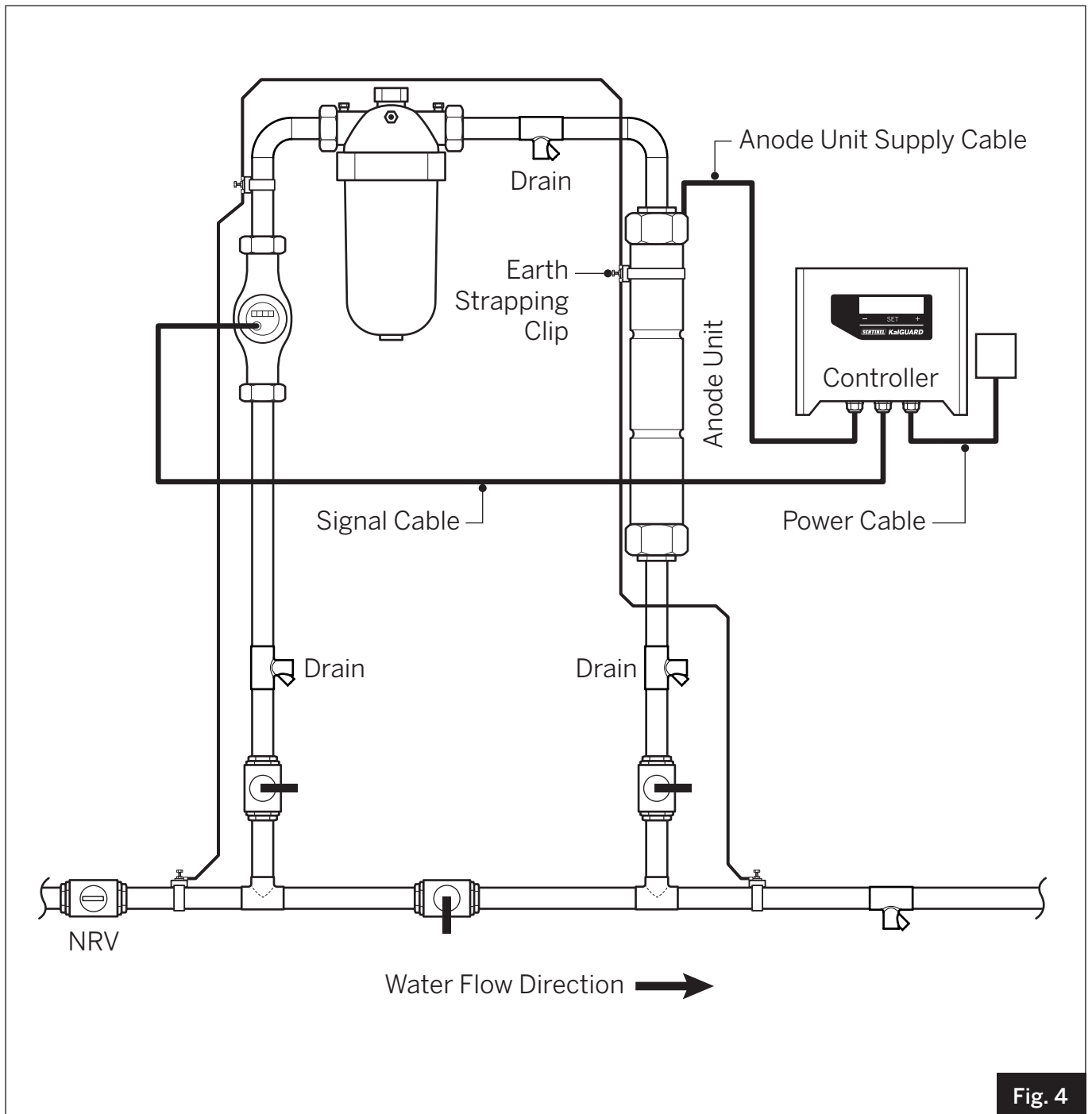

Fig. 4

Installation Advice

INSTALLATION SCHEMATICS (continued)

Schematic 3: Vertical Pipe

For vertical pipe when main water feed comes through the floor.

This installation should be considered when the main water feed comes through the floor.

Servicing the filter requires 50mm vertical clearance for removal of the filter bowl. There must also be good access to the anode unit. Access for periodic inspection of electrical components should also be available.

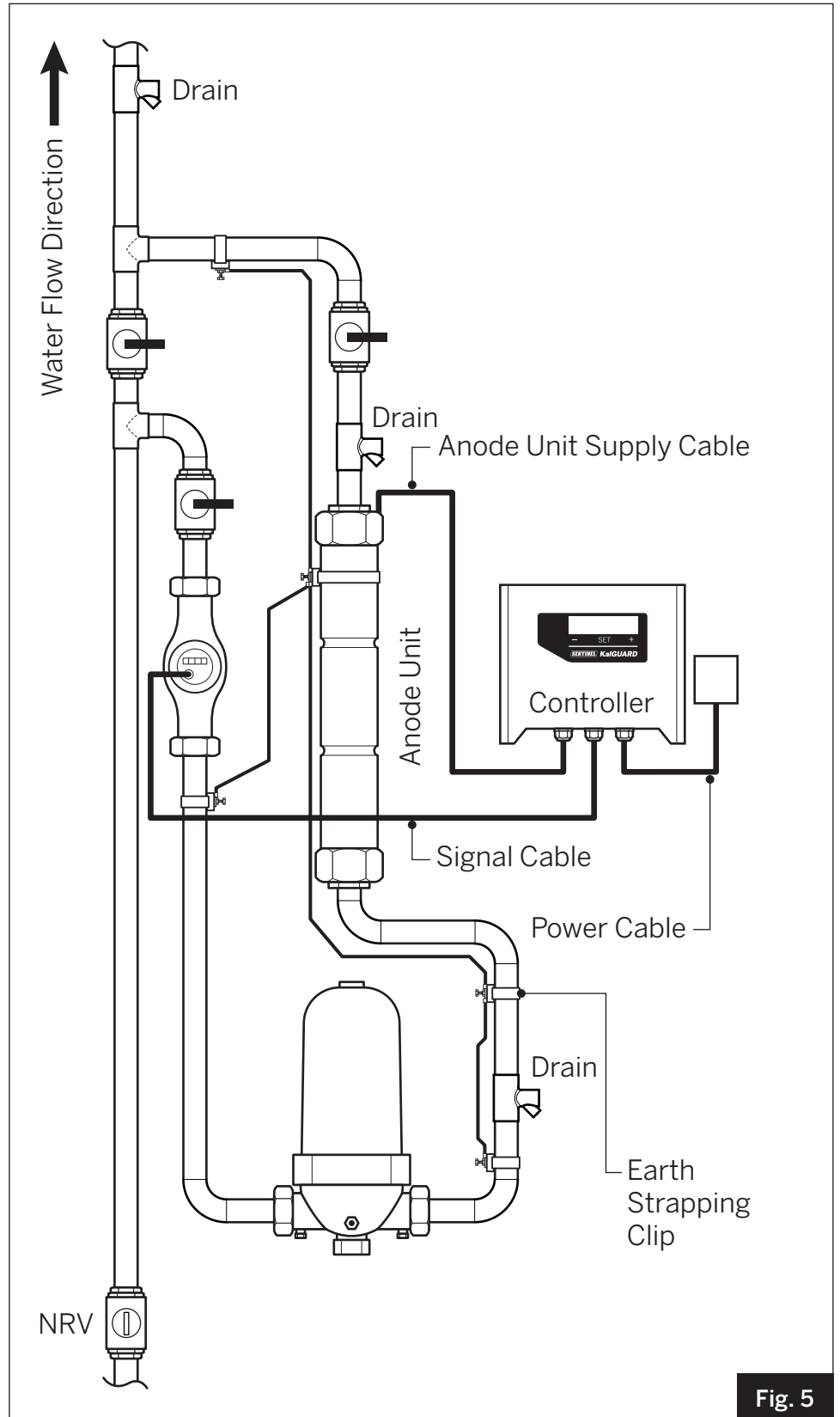

Fig. 5

CONCLUDING THE INSTALLATION

Following the completion of the pipework layout and mounting of the main components, conclude the installation by undertaking the following steps:

1. The 230/240 v 50Hz single phase electrical supply should be via a MCB distribution board (or similar) rated at 5A. An electrical switched fused 'spur' should be mounted on a suitable nearby surface within three metres of the KalGUARD assembly.
2. All cables should be connected as depicted in the schematic diagrams.
 - The cables should be secured with appropriate fixings to the supporting structure and should NOT be left loose.
 - **The water meter cable is three metres long and should be connected into the controller terminal chamber as per figures 7 & 10 (dependant on controller).**
 - The controller output cable should be connected onto the anode unit. The cable has a '2 offset pin' plug to connect into the socket found on the flat end shoulder of the anode unit. Take care connecting the plug to avoid damaging the connection pins. Rotate the plug until it enters the socket and then tighten down the locking ring until it is 'finger tight'.
 - In the event that the socket is partly obscured by plumbing components, the installer should endeavour to line-up the hexagonal flats of the coupler to provide a flat surface next the socket. Should there be a slight flange edge on the coupler that still obscures the socket, it should be removed with a file to provide free access to the socket.
 - Where it is required that a BMS system can receive data signals from the KalGUARD, a KalGUARD Pulse Splitter can be incorporated which is available from Sentinel as an accessory.
3. Ensure that the KalGUARD has water flowing through it. Water supply to the building may now be diverted via the side-stream pipework, though the by-pass valve should be only half closed to allow some water to pass through it until the anode unit is fully commissioned.
4. **The anode unit is ready to be COMMISSIONED by a commissioning engineer.** Please check through the list on the following page to ensure that all actions have been completed before contacting Sentinel Commercial as advised there.
5. The KalGUARD system must be correctly **COMMISSIONED**. After successful commissioning, a **CERTIFICATE** that records essential data and water treatment settings will subsequently be issued to the end user.

PIPEWORK SANITATION

When sanitation of the pipework on a new site is undertaken, it is safe for all of the KalGUARD equipment to be similarly treated.

Installation Advice

PREPARING THE KALGUARD FOR COMMISSIONING

Once all components are mounted, but prior to commissioning the system, the controller needs to be ready to power up. The installation engineer must ensure that all of the actions in the check list below are completed.

- 1. Is the KalGUARD kit mounted in a side-stream arrangement?
- 2. Is the water meter in the **same water flow line** as per Fig. 1?
- 3. Is the water filter mounted in the side-stream?
- 4. Is the filter mounted up-stream of the anode unit?
- 5. Is the water meter cable connected to the controller?
- 6. Is the controller output cable connected to the anode unit?
- 7. Is the water supply working?
- 8. Has the side-stream valve been fully opened to have water flowing through the side-stream, with the by-pass valve half closed?
- 9. Is the power supply available to the controller?
- 10. Is it supplied from an MCB distribution board?
- 11. Is the MCB rated at 5 amps or less?

When the check list is completed, please ensure the power supply to the KalGUARD is turned 'off' before calling Sentinel Commercial on 01928 704 330 and **requesting a Commissioning Engineer** to attend site to commission and confirm warranty and equipment status.

A certificate then will be issued to this effect from our Head Office to the responsible contractor.

MK1 KALGUARD CONTROLLER

The MK1 controller should only be used in conjunction with the 67mm KalGUARD, the 76mm KalGUARD and the 108mm KalGUARD.

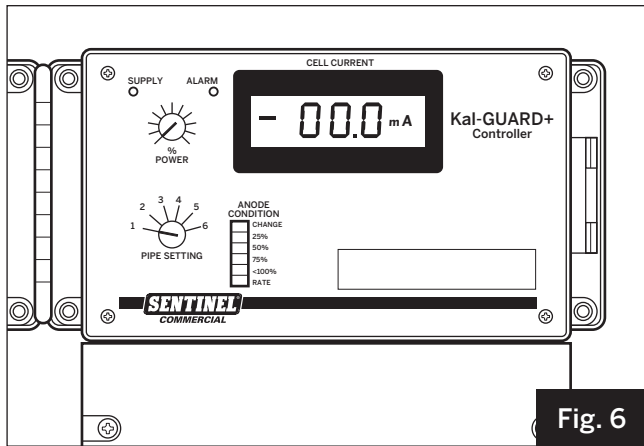

The function of the electronics in this equipment is to accurately control the release of zinc ions into the water-flow which provide effective treatment of the water to overcome limescale problems associated with very hard water supplies.

It is also designed to work intelligently by matching zinc output to water flow rate as measured by the water meter.

This equipment is designed to work on either 110/120v 60Hz or 230/240 v 50Hz single phase supply. The controller will normally have been set for 230/240v 50Hz supply (European setting).



WARNING: The circuit board has live connections and should only be accessed by a competent person.

An LED light confirms power is 'ON' and that the anode unit is functioning correctly.

In the event of the zinc electrode requiring service, another LED (showing 'ALARM') will light and immediate action should be taken to rectify the problem. Contact Sentinel on 01928 704 330.

Correct Operating Voltage

Isolate the incoming mains supply before connecting to the controller.

The controller will normally have a default setting for 230/240v 50Hz supply (European setting). This is set by a 'slide' switch below the transformer. This can only be seen with the controller printed aluminium front plate being unscrewed and gently removed.

To change this to 110/120v 60Hz (US setting), remove the printed front plate to expose the switch. The switch top displays the selected voltage. Slide the switch to the alternative position and the '110v' setting is displayed.

Power Supply Connection Point UK

For the UK, a switched fused spur output (rated 13A), with separate and remote isolation.

Power Connection Point on the Controller

The power cable to the controller should be connected to the 'LIVE', 'NEUTRAL' and 'EARTH' terminals on terminal block JP2, found under the cable entry terminal cover. All new controllers come with a 2 metre power cable.

The electrical supply should be provided via an MCB distribution board and the miniature circuit-breaker rating should be no more than 5A, or no less than 1A.

Technical Description: MK1 Controller

Functions within the Terminal Enclosure

Removing the cover from the terminal section of the controller exposes various connection points and other functions.

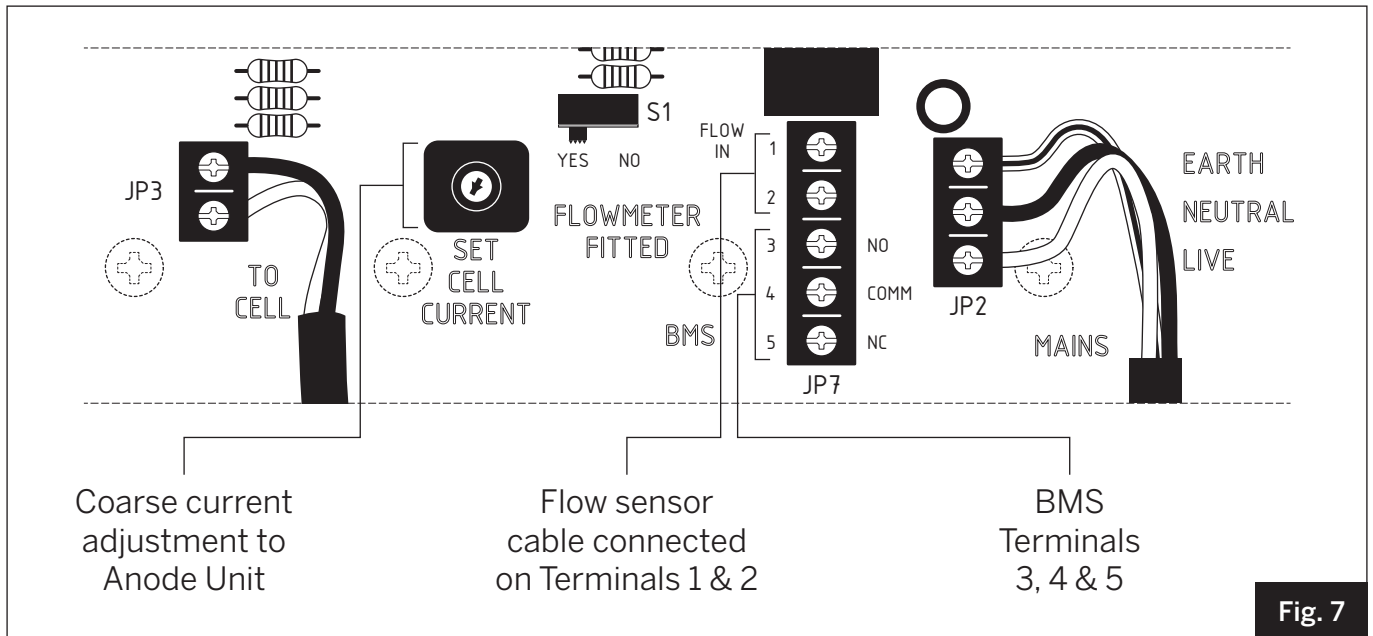

Connections and switches within the Terminal enclosure will be correctly set by the commissioning engineer when the controller is COMMISSIONED and apart from wiring in the water flow sensor cable, no other connections or changes should be undertaken by the installation engineer.

The information below is for advice purposes only. The various functions found in the terminal enclosure are:

1. To Anode Unit

This is the terminal (JP3) to attach the output control cable connecting the 'In-line' treatment anode unit. **Please note the 'blue' cable attaches to the '+' (positive) terminal, whilst the 'brown' cable attaches to the '-' (negative) terminal.**

2. Set Anode Unit Current

This is a coarse control to ensure the fine setting adjuster on the top left hand corner of the controller can operate effectively. This will be set during COMMISSIONING and should not be adjusted by the end-user without consultation with the manufacturer.

3. Water Meter Fitted

S1 is set to "YES" once the water meter is fitted. The water meter is fitted in the pipework and connected by its integral cable to the controller. The water meter cable should be connected to terminal array JP7 (found in the centre of the board) on to positions 1 & 2. For 2" water meters and smaller connect the red cable to position 1 and the black cable to position 2. For 2½" water meters and above connect the white cable to position 1 and the grey cable to position 2 and discard all the other wires.

MK1 KALGUARD CONTROLLER (continued)

4. BMS Monitoring Fault Mode

This BMS function is to warn whether the controller is in a fault mode. Such a fault would indicate that the anode unit is no longer working. This can be used if there is a BMS central monitoring station for the building/plant. Positions 3, 4 & 5 on terminal JP7 connect to a no-volt changeover contact. A signal provided externally to the controller can be controlled through this switch. The MK1 controller has the following rating for the BMS output:

- 1.0A 24V DC
- 0.5A 125V AC

5. BMS Monitoring Water Usage

Should accurate flow measurement/water usage be a requirement of the BMS system, then the a KalGUARD Pulse Splitter can be incorporated, which is available from Sentinel as an accessory. Further details can be found on the Sentinel website.

6. F2

Found just right of terminals JP2, is a secondary ½" control-gear back-up fuse, rated at 500 mA.s, and will be the first fuse to fail, should it happen.

Technical Description: MK2 Controller

MK2 KALGUARD CONTROLLER

The MK2 controller should only be used in conjunction with the 22mm KalGUARD, the 28mm KalGUARD, the 35mm KalGUARD, the 42mm KalGUARD and the 54mm KalGUARD.

The function of the electronics in this equipment is to accurately control the release of zinc ions into the water-flow which provide effective treatment of the water to overcome limescale problems associated with very hard water supplies.

It is also designed to work intelligently by matching zinc output to water flow rate as measured by the water meter unit.

This equipment is designed to work on a 230/240 v 50Hz single phase supply only.



WARNING: The circuit board has live connections and should only be accessed by a qualified electrician.

Mains Power Connection

A switched fused spur output (rated 13A), with separate and remote isolation is required to power the unit. The electrical supply should be provided via an MCB distribution board and the miniature circuit-breaker rating should be no more than 5A, or no less than 1A.

The power cable to the controller should be connected to the 'LIVE' and 'NEUTRAL' positions on terminal block J1, found within the terminal access bay. Once connected, the OLED display will automatically illuminate confirming that power is 'ON'.

Electrical Connections to Anode Unit, Water Meter and BMS

As shown in Fig. 9, the terminal bay is exposed by opening the front cover of the controller, which is retained with a single tamper proof screw. A special driver bit is supplied with the unit. See Fig. 10 for the relevant pin orientation. Apart from the wiring to the mains, anode unit, water meter and BMS (where used), no other connections or changes should be undertaken by the installation engineer. The information below is for advice purposes only.

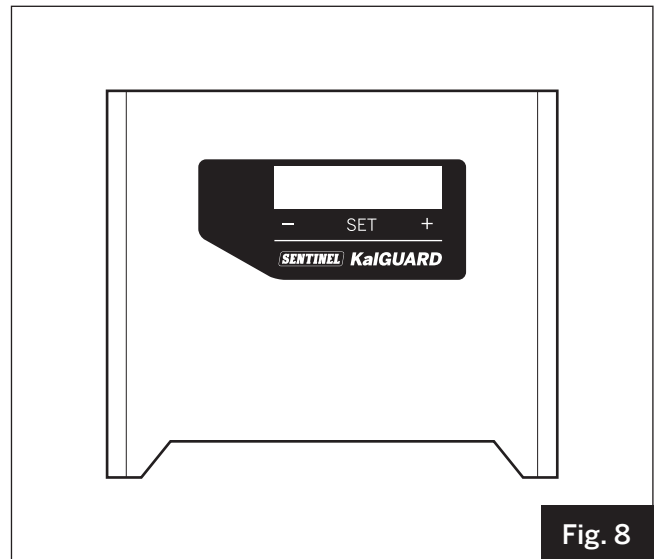

Fig. 8

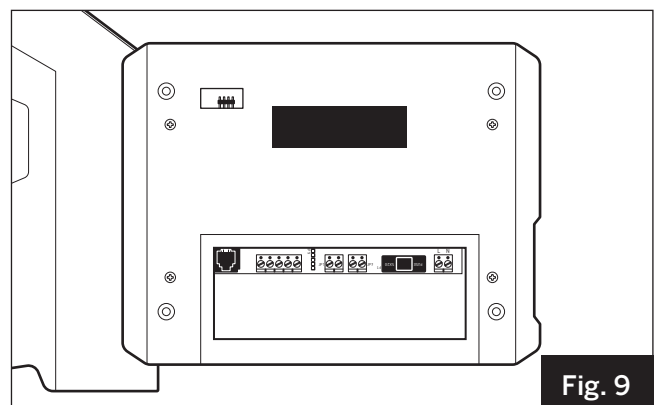

Fig. 9

MK2 KALGUARD CONTROLLER (cont.)

Primary Connections

- To Anode Unit**

Terminal JP7 is to connect the output control cable to the anode unit. Please note that the brown wire attaches to the '+' terminal, whilst the blue wire attaches to the '-' terminal. See Fig. 10 for details.

- To Water Meter**

Terminal JP1 is the connection point for the KalGUARD flow meter. For 2" water meters and smaller connect the red and black cable to position JP1. For 2 1/2" water meters and above connect the white and grey cable to position JP1 and discard all the other wires. The meter is supplied with a suitable cable – the polarity is unimportant.

Optional BMS Connections

- Controller Override**

If required, the KalGUARD controller can be switched on and off remotely via a BMS. The relevant terminals are shown in Fig. 10.

- BMS Monitoring (Faults)**

The BMS fault monitoring function can be used to warn that there is a fault condition displayed on the front panel. This connection can be used if there is

a BMS central monitoring station for the building. Terminals 1 & 2 (see Fig. 10) connect to a no-volt changeover contact. An external signal can be controlled through this switch. The Mk2 controller has a rating of 0.2A 60V for the BMS output.

- BMS Monitoring (Water Usage)**

Should accurate flow measurement / water usage be a requirement of the BMS system, then a KalGUARD Pulse Splitter can be incorporated, which is available from Sentinel as an accessory. See the Sentinel website for details.

Fuse

Found just to the left of the mains connection terminal is a 1A quick blow 20mm fuse rated for mains use.

Starting Up

- Ensure controller is connected to the mains and powered up.
- A message will immediately appear on the first start-up only, prompting the installer to contact Sentinel for commissioning.

If in any doubt, please contact Sentinel on 01928 704 330.

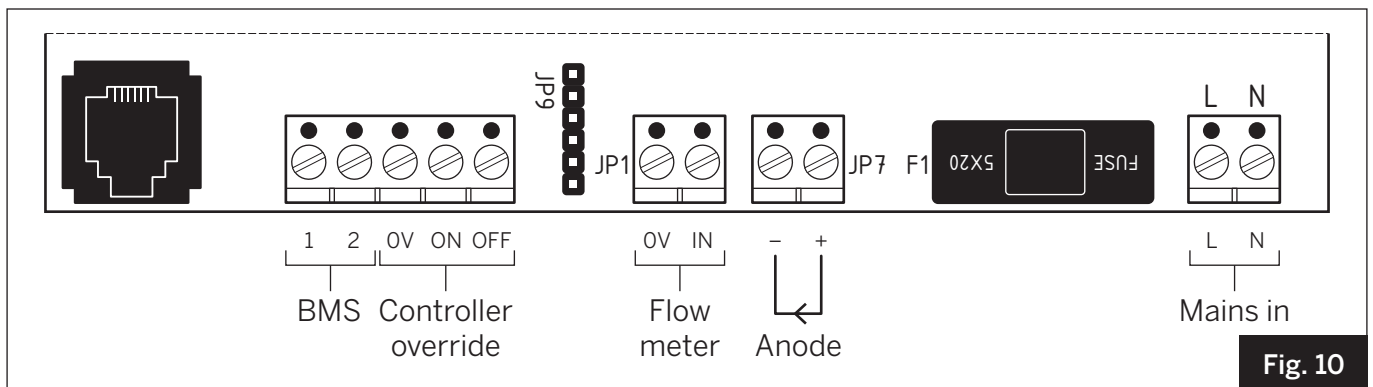

Fig. 10

Water Meter

USING A WATER METER TO CONTROL THE WATER TREATMENT PROCESS

A water meter, as shown in Fig. 11, is supplied by Sentinel Commercial as part of the KalGUARD system and it is intended to work with the KalGUARD controller.

It is a critical system component which provides essential data to the controller and in combination provides intelligent control of the anode unit.

It is NOT intended for paralleling with a BMS for volumetric water measurements. See note 5 on Page 17 for BMS coupling.

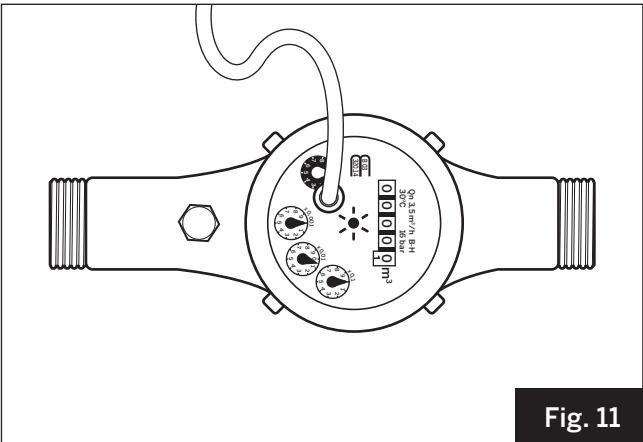

Fig. 11

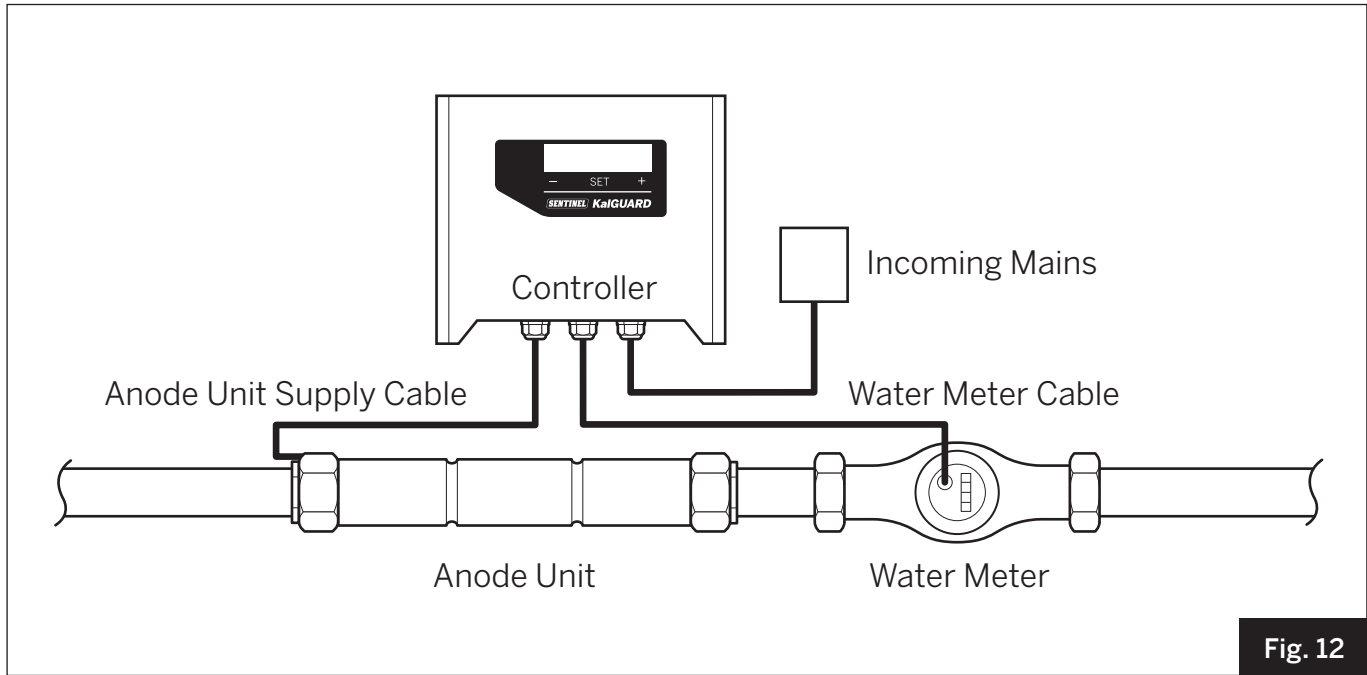

Fig. 12

WATER FILTRATION

Water filtration is recommended. For optimum water treatment and guaranteed performance, the incoming mains water supply should be filtered with a 50µm (or finer) sediment cartridge. If upstream filtration to this standard is already in place, there is no need to install extra filters.

For all pipe sizes up to 108mm (4") Sentinel Commercial supply filters of the 'stacked disk' type.

Single bowl filters are supplied up to 54mm size KaIGUARD and double bowl filters for 67mm and above. See Fig. 1 and Fig. 2 for single bowl filters and recommended installation. See Fig. 13 for double bowl filter and recommended installation. These can be cleaned by simply dismantling and rinsing through. It is recommended that

filter cleaning is undertaken periodically – at least at six monthly intervals. Inspect a newly installed filter regularly within its first few months of use to estimate the required ongoing cleaning interval. The 'stacked disc' assembly should be carefully inspected annually and replaced if necessary. Spares for these filters are supplied by Sentinel Commercial. Call 01928 704 330 for further details.

PLEASE NOTE: The 2" filter has a blank cap which should never be removed. If the tamper seal is damaged the warranty is then void.

Technical Questions

Please contact our office on 01928 704 330 should you have any questions.

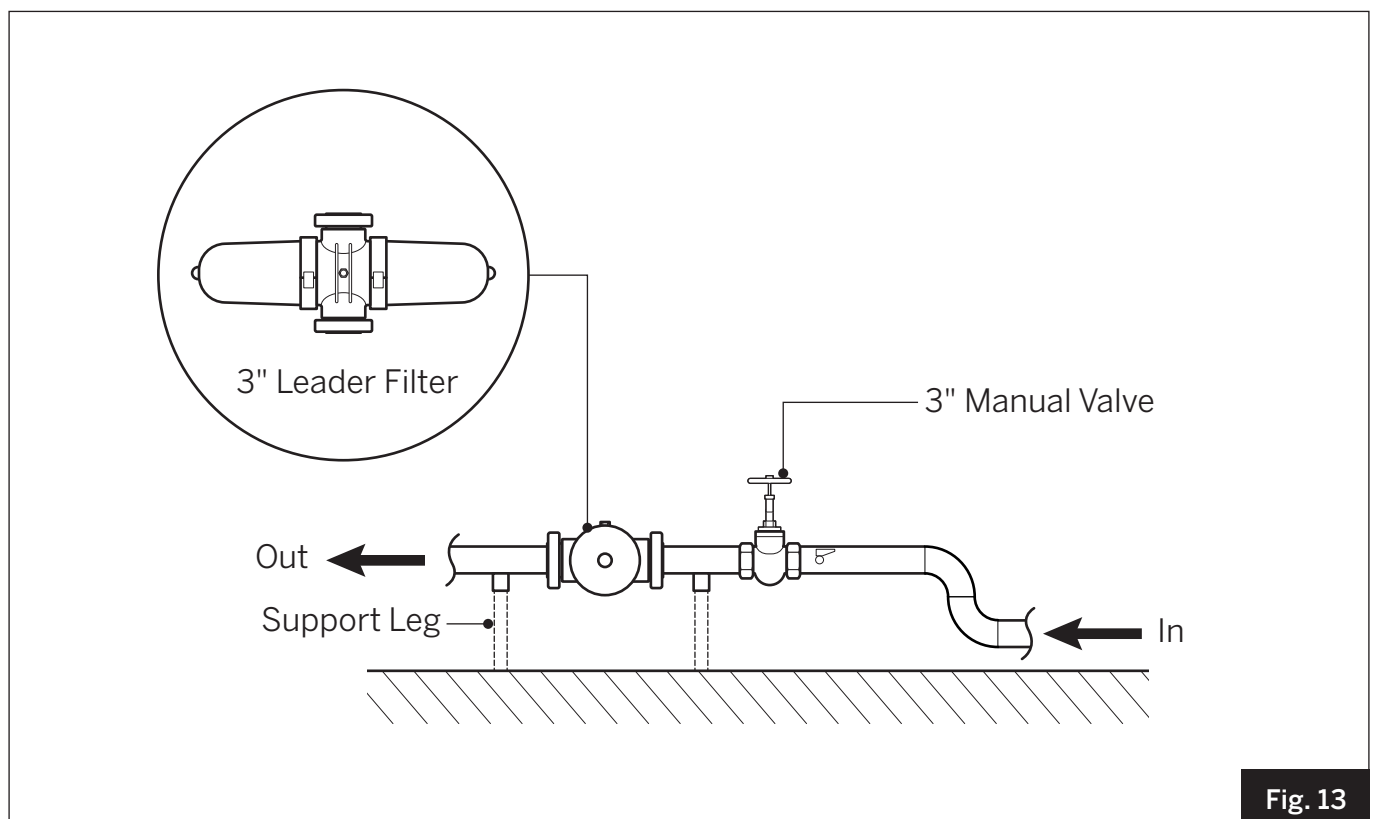

Fig. 13

Pulse Splitter User Instructions

INTRODUCTION

The pulse splitter is designed to simultaneously feed the signal from the water meter to both the KalGUARD controller and a Building Management System (BMS). It can be used with any size of KalGUARD, water meter and both versions of the controller. The outputs are identical and completely isolated so there is no risk of interference.

Please refer to Fig. 14 which shows how the Pulse Splitter is integrated into the KalGUARD, controller and water meter.

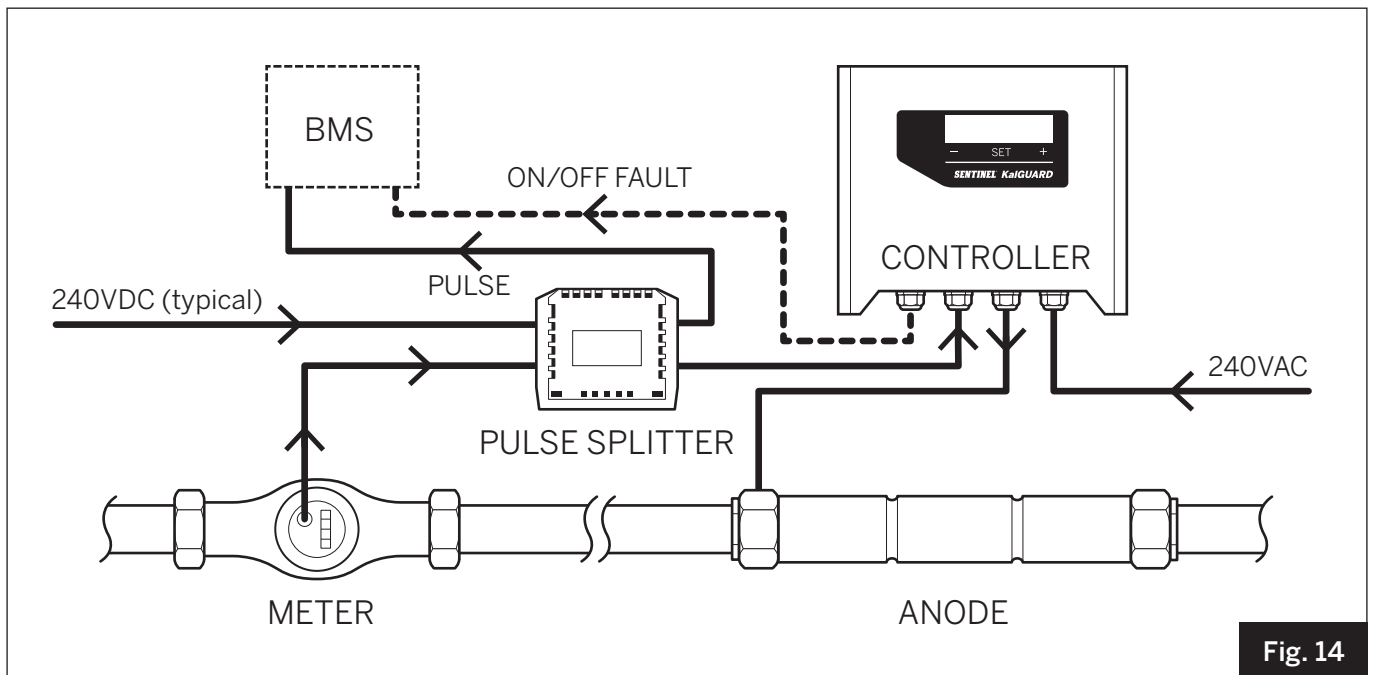

Fig. 14

SPECIFICATION

- Power Supply: Min = 7V, Max = 30V, typical = 24V@25mA
- Resistance: Max = 0.2R, typical = 0R
- Switch Power: 10V
- Operating Temperature: Min = -20°C, Max = +85°C
- Connections: Rising clamp terminals with 3.5 x 2.5mm apertures
- EMC: Tested to BS EN 61000-4-21:2011
- Dimensions: H (on rail) = 72mm, W = 18mm, D = 62mm
- Casing: Grey flame retardant resistant polyamide

INSTALLATION

Prior to installation ensure the following:

1. Unit must be securely mounted in an IP65 rated housing to prevent water / dust ingress.
2. Ensure easy access to the component.
3. Ensure the component is stable upon installation with minimum vibration.
4. Ensure no contact with other electromagnetic components or close connections to minimise interference.
5. Where there is need to protect the circuit as part of a big system then connect a fuse.

Pulse Splitter User Instructions

WIRING

Please refer to schematic outlined in Fig. 15 before wiring. Ensure that the wiring is connected as follows, as incorrect wiring could result in shorting.

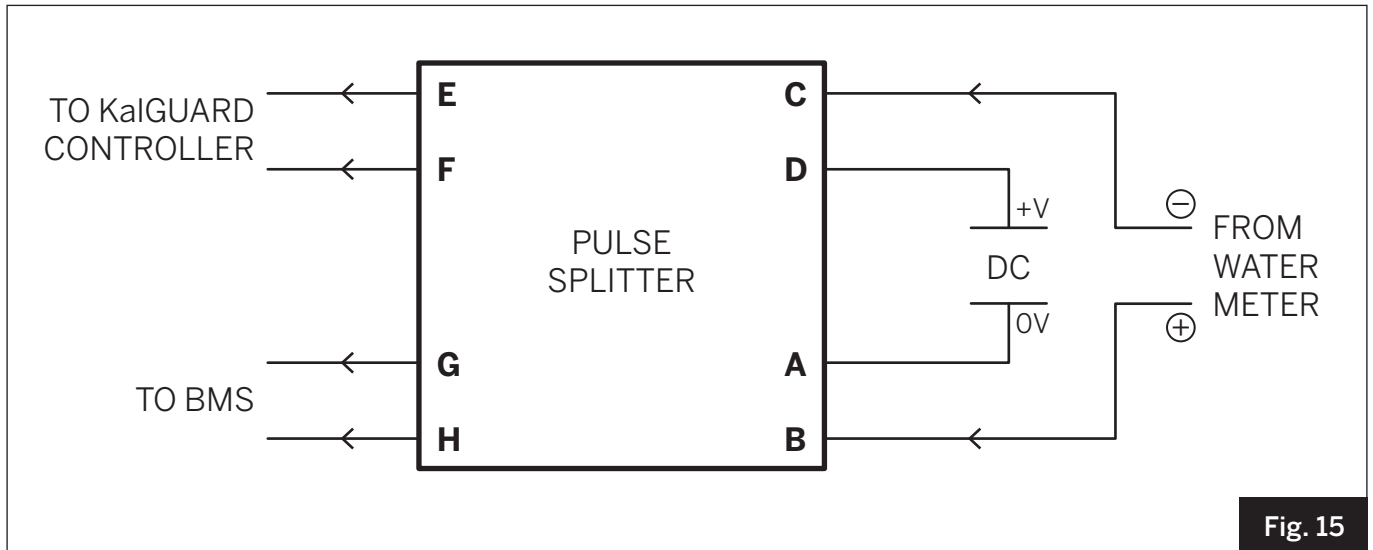

Terminal	Connection
A	0V
B	IN + (from water meter)
C	IN – (from water meter)
D	+V
E	RLY 1 (controller)
F	RLY 1 (controller)
G	RLY 2 (BMS)
H	RLY 2 (BMS)

The terminals which the controller and BMS are wired respectively can be switched around if needs be, but terminals E&F and G&H must be paired up.

Health & Safety

HEALTH & SAFETY

Zinc in Drinking Water Supplies

This equipment is designed to add a very small amount of ionic zinc to the water supply. The anode unit adds up to 50 parts per billion (0.05 milligrammes/litre). This is perfectly safe for health.

The World Health Organisation and water authorities in the UK and within the EU allow a maximum of 5 milligrammes/litre (5,000 parts per billion) of zinc in drinking water which is 100 times more than added by KalGUARD. Zinc is considered to be beneficial to health and is an essential trace element found in virtually all food and potable water in the form of salts or organic complexes.

The human body needs zinc for healthy functioning, usually provided via food and drink, and the daily requirement is about 15-20 milligrammes. KalGUARD is approved for use on potable water systems by the Water Regulations Advisory Scheme (WRAS).

SERVICING CONTRACT

It is important to undertake regular servicing of any sophisticated water treatment equipment to maintain optimum operation and efficacy. The equipment should be checked every six months and filters cleaned. The system ought to be fully inspected to ensure that all aspects of its functioning are monitored, logged and if required, reset. This will ensure that the anode unit operates at its optimum efficiency to complement your system. Details of Sentinel Commercial's service contract can be found below.

RECOMMENDED MONITORING

Weekly

Partially open the side-stream loop by-pass valve to flush the by-pass pipe section and avoid a dead area for the proliferation of bacteria. This operation is in accordance with L8 compliance obligations embodying the requirements of the Health and Safety at Work, etc. Act 1974 (HSWA) and the Control of Substances Hazardous to Health Regulations 1999 (COSHH) concerning the risk from exposure to legionella bacteria. The operation should be included in any standard weekly flushing regime recorded in your water hygiene site logbook.

If the MK1 controller is in an alarm state, consult the trouble-shooting section on Page 25 for the appropriate action to take. In instances where the MK2 is in an alarm state, refer to Page 19 'Trouble Shooting'. A record of actions on reporting and rectifying should be made in the Service Logbook. If necessary, contact Sentinel Commercial on 01928 704 330 for advice. On completion of the quarterly check ensure that the controller is not in a state of alarm and record this in the Service Log below.

Half yearly (or more often in poor water quality supplies)

Ensure filter cleaning is undertaken. Simultaneously, enter details of this in the Service Log at the back of these instructions. All activities should also be entered in the site/building maintenance Logbook if available.

OTHER SERVICE CONSIDERATIONS

After several years of operation - On the MK1 Controller

When the indicator shows 'CHANGE', contact Sentinel Commercial Technical Department on 01928 704 330. After several years, the indicator on the controller may gradually illuminate. This signals the onset of anode unit exhaustion although the controller will continue to operate satisfactorily for several months further. Our service team can visit your site to replace the exhausted anode unit at your convenience.

AUTOMATIC SERVICING

A service contract established within a year of commissioning, will cover all the above. The service visit is carried out every six months to ensure a sound functioning environment. Agreeing a service contract will extend the product guarantee into a third year.

Commissioning Details

COMMISSIONING DETAILS

Date of installation	
Name & contact details of installer	
Location of installation	
KaIGUARD model installed and serial number	
Water meter fitted and serial number	
Water meter reading	
Water volume / day	
Estimated flow rate	
Usage hours per day	
Amperage reading (mA)	
Type and size of filter	
Water hardness and pH	
Person commissioning	

TROUBLE SHOOTING (MK1 CONTROLLER ONLY)

Item	Fault	Likely Reason	Action
1	No lights showing on the Controller.	No power supply or power interrupted leading to the controller.	<ul style="list-style-type: none"> • Make sure the controller has power and that it is turned on. • Check main fuse / MCB board is providing power. • Check fuse in the switched fuse spur, and replace if faulty. • Investigate the fuse inside the lower terminal cover on the controller. Replace if necessary. Two spare fuses are provided with the controller.
2	The alarm is sounding.	The output from the controller is not reaching the anode unit.	<ul style="list-style-type: none"> • Check output cable is plugged into the anode unit and its threaded locking head is finger tight. • Has a filter been fitted? If not, then the anode unit may be dirty. It should be cleaned. • Call Sentinel Commercial on 01928 704 330 for further advice.
3	The alarm has previously been intermittently sounding and is now firmly on.	Local water dosing (varying water chemistry) may have caused issues with the anode unit.	<ul style="list-style-type: none"> • The anode unit may need flushing with a cleaning agent. • Call Sentinel Commercial on 01928 704 330 for further advice. A service may be required.
4	Water flow has reduced or stopped.	<p>Water is being restricted.</p> <p>Filter cartridge needs replacing.</p>	<ul style="list-style-type: none"> • Isolate the side-stream loop and open the bypass valve to verify that supply water is flowing again (operate a mains feed tap). If flow is re-established, clean the filter element. • Call Sentinel Commercial on 01928 704 330 and ask to speak with filter sales. Your site may be logged on our database and a filter can be sent to you.

Should you need assistance, please call **01928 704 330** and ask to speak with the Technical Department, who will then advise you further.

Trouble Shooting

TROUBLE SHOOTING (MK 2 CONTROLLER ONLY)

Fault Code	Causes and Actions
F01: Anode Unit Fault	<p>The alarm for an anode fault consists of an F01 fault code on the screen and an audible buzzer. Where connected, a relay operation will be triggered to instruct the Building Management System of 'a fault' with the installation.</p> <p>The anode unit should normally only fail due to long term depletion, after 10 – 12 years or longer dependent on usage. Fouling is also possible as a result of inappropriate set-up during commissioning - or possibly a contaminated water supply. A damaged or disconnected cable would also result in this fault condition.</p> <p>Once the root cause is established (and corrected), the fault condition will automatically de-activate. Since an F01 fault is associated with either depletion or fouling of the anode unit, it is strongly recommended that the user contacts Sentinel immediately on 01928 704 330 to discuss.</p>
F02: Anode Unit Disconnected	<p>If the anode unit becomes inadvertently disconnected, the controller will respond by automatically generating an F02 error message on the screen. A buzzer will also sound and a relay will be closed to instruct the BMS of 'a fault' (where connected).</p> <p>To clear the fault, the anode unit must be correctly reconnected (or the wires repaired).</p>
F03: Water Meter Disconnection	<p>On initial set-up, the controller will look for a pulse from the water meter. Unless water is actually flowing when the unit is commissioned, an F03 code will be displayed on the screen and a buzzer will be sounded. Where connected, a signal will also be sent to the BMS that there is 'a fault' with the installation.</p> <p>Should more than a seven day period ever pass without a pulse occurring from the meter, the controller will generate an F03 error, sound the buzzer and send a signal to the BMS, where connected.</p> <p>The F03 fault condition will only be resolved once a pulse is detected, confirming the meter is in place, which would occur once flow takes place and the meter is correctly installed.</p>
F04	Contact Sentinel immediately on 01928 704 330
F05	Contact Sentinel immediately on 01928 704 330

SERVICE LOG: SHEET 1

All actions taken with this equipment after it has been installed and commissioned should be entered into this log, and then duplicated in the Water Hygiene Site Logbook, as a back-up to this record. (Please copy page 29 of this manual should you need additional copies to cover a period longer than that accommodated here.)

Date	Service need	Action taken
		 Action taken by:
		 Action taken by:
		 Action taken by:
		 Action taken by:
		 Action taken by:
		 Action taken by:

Service Log

SERVICE LOG: SHEET 2

All actions taken with this equipment after it has been installed and commissioned should be entered into this log, and then duplicated in the Water Hygiene Site Logbook, as a back-up to this record. (Please copy page 28 of this manual should you need additional copies to cover a period longer than that accommodated here.)

Date	Service need	Action taken
		<div style="border: 1px solid black; height: 100px;"></div>
		Action taken by:
		<div style="border: 1px solid black; height: 100px;"></div>
		Action taken by:
		<div style="border: 1px solid black; height: 100px;"></div>
		Action taken by:
		<div style="border: 1px solid black; height: 100px;"></div>
		Action taken by:
		<div style="border: 1px solid black; height: 100px;"></div>
		Action taken by:

SERVICE LOG: SHEET

All actions taken with this equipment after it has been installed and commissioned should be entered into this log, and then duplicated in the Water Hygiene Site Logbook, as a back-up to this record. (Please copy this page should you need additional copies to cover a period longer than that accommodated here.)

Date	Service need	Action taken
		<div style="border: 1px solid black; height: 80px; width: 100%;"></div>
		Action taken by:
		<div style="border: 1px solid black; height: 80px; width: 100%;"></div>
		Action taken by:
		<div style="border: 1px solid black; height: 80px; width: 100%;"></div>
		Action taken by:
		<div style="border: 1px solid black; height: 80px; width: 100%;"></div>
		Action taken by:
		<div style="border: 1px solid black; height: 80px; width: 100%;"></div>
		Action taken by:
		<div style="border: 1px solid black; height: 80px; width: 100%;"></div>
		Action taken by:

Salamander (Engineering) Ltd
T/A Sentinel Commercial
7650 Daresbury Park
Warrington
Cheshire
WA4 4BS

Tel +44 (0) 1928 704 330
www.sentinelprotects.com